

Model No. TM-358

TYPE: Self-supporting, extendable, motorized tubular mast.
Designed for light weight antenna loads.

SPECIFICATIONS:

TUBULAR MAST HEIGHT: Extended 58'. Retracted 23'.

WIND LOADING: Engineering analysis indicates the tower will support an antenna with an equivalent effective projected area of 10-ft² at a basic wind speed of 100 MPH, 3-second gust per ANSI/TIA-222-H., Exposure C, No Crest, Topo 1.

DEAD LOAD: The maximum antenna dead load is 500 lbs.

WEIGHT: The mast with the base weighs 1,750 pounds.

SECTIONS: The mast is made from 6", 4", and 2 1/2" pipe, $F_y = 50$ ksi

DESCRIPTION:

Tubular mast is complete with a 40:1 gearbox, 3/4 hp, 110V electric motor, 1/4" x 7 x 19 aircraft lift cable lift system and a hinged concrete base mount. The mast is designed to extend the tubular telescopic sections uniformly. A user's manual is included.

Tubular mast include a hinged base mount that is installed in concrete. This base mount allows the tower to be hinged at ground level and tilted into a vertical position.

The TM towers are hot-dipped galvanized after fabrication for maintenance free finish.

The top section of the mast is adapted to accept an accessory rotator cage assembly. If a rotator assembly is not used, the mast adapter can be ordered as an accessory item. All standard mast adapters accommodate a two (2) inch O.D. mast size.

ACCESSORIES:

- TM-358 manual, Drawings, Calculations
- TM-358 Concrete Base
- CO-3 for TM
- Work Platform
- Tilting Gin Pole
- Rotator Cage Assembly
- Cable Kit
- Motor Control Assembly
- TB-2 Thrust Bearing
- Remote Control Kit

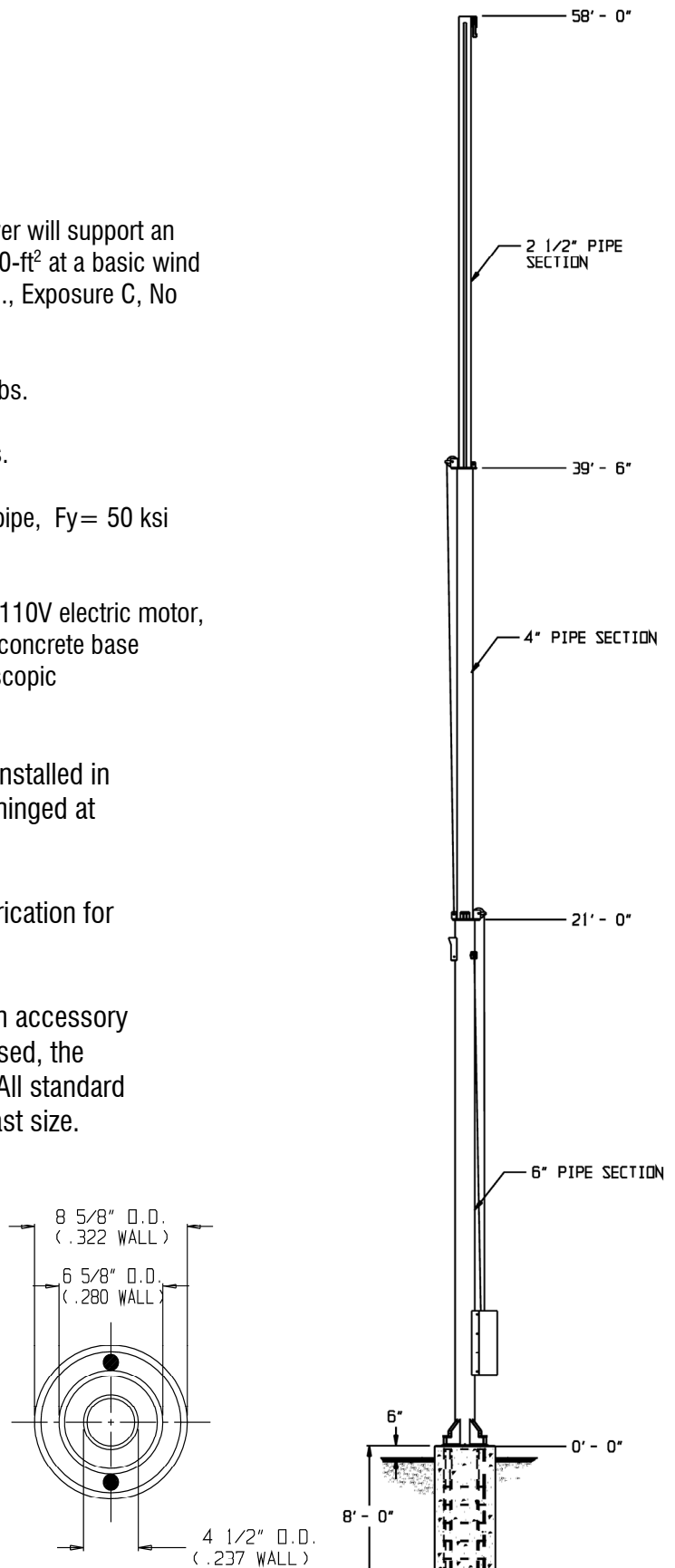

CROSS SECTION

PART# 525-4000 \$9,099.00 USD