

# Model No. LM-354HD and HDSP

**PART NUMBER:** 454-00402 MANUAL  
454-00409 MOTORIZED

**TYPE:** Self-supporting, extendable, crank-up tower.

**SPECIFICATIONS:**

**TOWER HEIGHT:** Extended 54'. Retracted 21'-6"

**TOWER SUPPORT:** Self-supporting, no guys.

**WIND LOADING:** Engineering analysis indicates the tower will support 45 square feet of projected area at the basic wind speed of 100 MPH, 3 second gust per ANSI/TIA EIA RS 222 Rev. H.

**DEAD LOAD:** The maximum dead load is 450 lbs.

**WEIGHT:** The tower with the base weighs 960 pounds.

**SECTIONS:** The tower is made from three each 20 foot sections #6, #7 and #8.

**DESCRIPTION:**

Tower is complete with a gearbox, drum and hoisting cables, and a rigid concrete base mount. The tower comes equipped with a manual and one set of drawings and calculations, hoisting cable system designed to extend the tower telescopic sections uniformly.

The LM-354HD uses a manual crank on the gearbox to extend and retract the tower. This tower does not have a positive pull down.

The LM-354HD SP is a motorized version of the above tower, the 1/2 HP electric motor comes with an electric control box and two limit switches. This tower has a positive pull down and has the largest top section offered.

"Positive Control" worm gear winch permits the raising and lowering of LM towers without the aid of stops or locks. LM-354HD uses a 40:1 ratio winch. The LM-354HDSP also includes a pre-wired motor control assembly.

This tower has a pulley frame on two faces. The lifting cable is 1/4 x 7 x 19 Aircraft cable.

**ACCESSORIES:**

- RCB-70LT (#8 Wide Section)
- Cable Kit for LM-354HD
- CO-3 for LM-354HD
- TA-70
- TB-2 Thrust Bearing
- Manual Winch
- #6 Rotator Plates

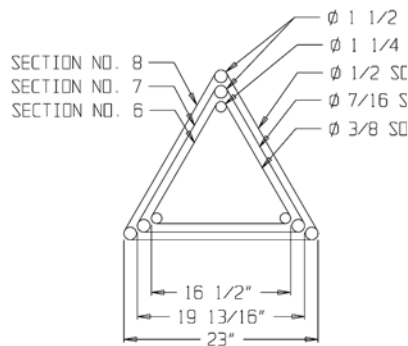

TOWER CROSS SECTION

